

# TQS-LI-BOTTLE

TECHNICAL DATA

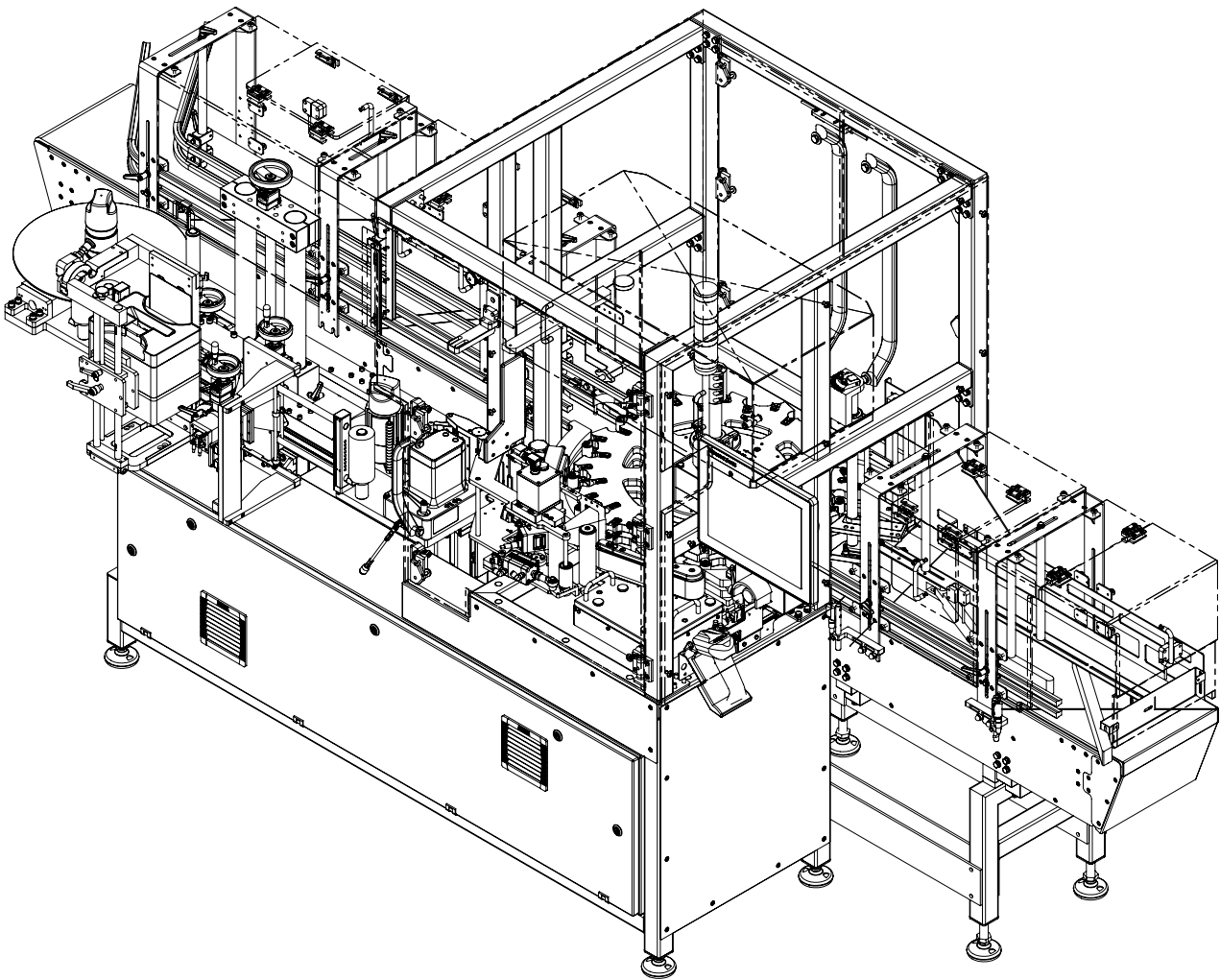

## BASE DATA

<b>Material of machine</b>	Stainless steel V2A/AISI 304
<b>Unit weight</b>	950 kg
<b>Production type</b>	IP54 <sup>1)</sup>
<b>Temperature range</b>	+5 °C to +40 °C
<b>Display and operation</b>	15" colour TFT display with touchscreen (optionally 19" colour TFT display with touchscreen)
<b>Interfaces</b>	Standard level 3 interface (XML, Ethernet)
<b>Output</b>	60 pcs/min (optionally 150 pcs/min)
<b>Product diameter (cylindric)</b>	30 mm-100 mm
<b>Product height</b>	20 mm-300 mm
<b>Product transport height</b>	800 mm-950 mm (optionally 700 mm-840 mm / 900 mm-1,050 mm)
<b>Drive</b>	Servomotor
<b>Length of the travel direction</b>	3,000 mm
<b>Rated voltage; Rated frequency</b>	L1/N/PE 100-240V; 50/60 Hz
<b>Connect load</b>	1 kVA
<b>Compressed air</b>	Approx. 6 bar 16 NI/min, purity class 5/3/3 to DIN ISO 8573-1

## OPTIONAL COMPONENTS

<b>Software and Connection</b>	TQS Line Manager, TQS Device Controller, Industrial firewall with remote maintenance, Data backup and recovery, meets requirements according to CFR 21 part 11, Microsoft Active Directory, customer-specific report, standardised universal interface for connection to level 3
<b>Aggregation level</b>	Manual extention (optional manual aggregation level)
<b>Handheld scanner</b>	Wireless
<b>Mark&amp;Verify Group</b>	Fully integrated thermal transfer label printer
<b>Sorting and Ejection</b>	Deflector to customer conveyer (lane deflector)
<b>Sorting lamp</b>	3-stage stacklight (optionally customer-specific signalling column)
<b>Language packs</b>	Bulgarian, Chinese (simplified), Croatian, Czech, Danish, Dutch, English, Estonian, French, German, Greek, Hungarian, Italian, Polish, Portuguese, Romanian, Russian, Spanish, Swedish, Turkish (other languages on request)
<b>Documentation</b>	Machine documentation, Qualification package, Functional specification (FDS), Risk analysis industrial personal computer (RA IPC), Traceability Matrix (TM), Risk analysis according to Machinery Directive (RAM)

<sup>1)</sup> water spray from above

These specifications are reference values of the standard machine excluding application- or weighing-specific add-on parts.  
Extended performance data available on request.

# MACHINE DIMENSIONS

## TQS-LI-BOTTLE

TQS LI-Bottle

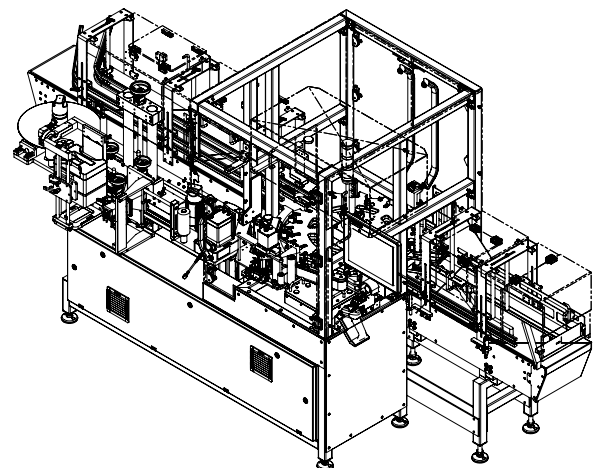
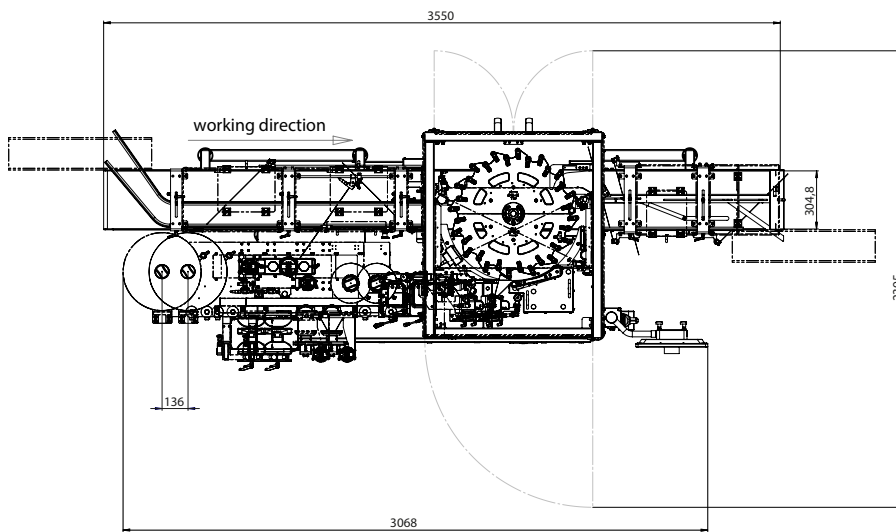
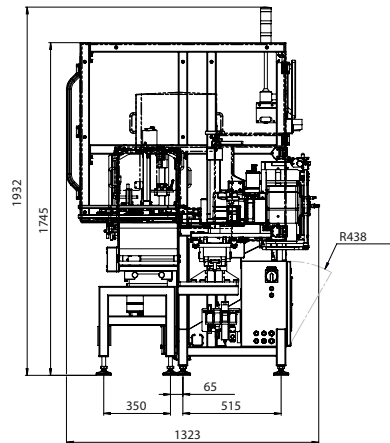
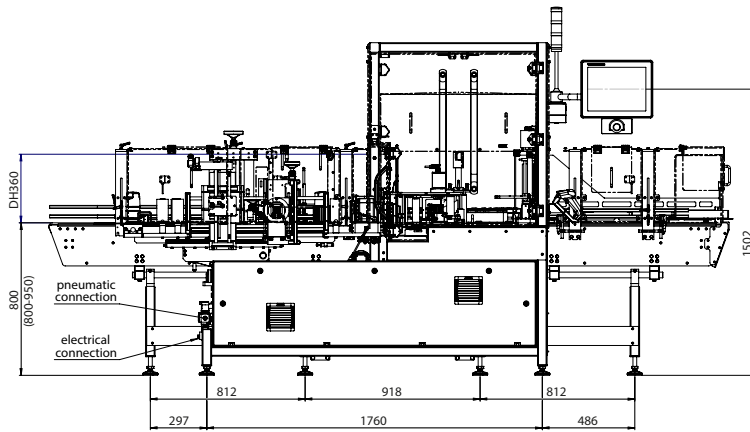

These specifications are reference values of the standard machine excluding application- or weighing-specific add-on parts.  
All entries in mm | Drawing shows design example

